

SCREEN MOUNT

TYPE CH-HL

The RESATEC screen mount type CH-PL is the optimization in terms of power density. Sufficient oscillation amplitudes, good insulating effect and good resistance with regard to spontaneous loading are retained. The support of inclined screens is also possible. If a belt drive is intended to drive the unbalance shafts, we recommend the use of a motor base (e.g. RESATEC motor base MW-8).

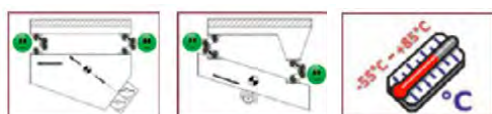
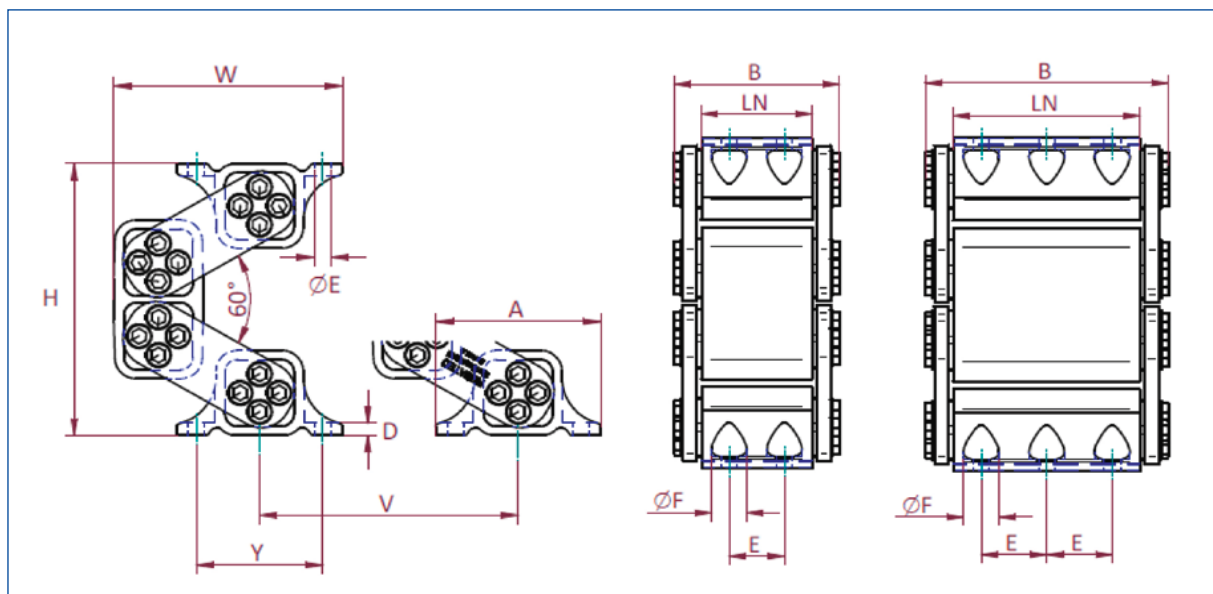

SCREEN MOUNT

TYPE CH-HL

dimensions																material		
type	H		W		A	B	LN	D	E	øE	screws	øF +/- 0.2	Y	V	weight	housing	core	lever
	unbe- lastet	max. Last	unbe- lastet	max. Last										min.	kg			
CH-I HL 3 – 40	102	126	86	76	65	52	40	4	-	7	4	-	50	80	1.0	SINT-C 40	1.4571	
CH-HL 7 – 110	259	321	210	183	145	145	110	8	65	13	8	-	115	220	7.9	aluminium	steel powder coating	
CH-HL 8 – 120	288	361	235	203	170	180	120	13	60	17	8	38	130	240	15.8		aluminium	steel with powder coating
CH-HL 8 – 160	288	361	235	203	170	220	160	13	2 x 60	17	12	38	130	240	18.3			
CH-HL 8 – 200	288	361	235	203	170	260	200	13	2 x 70	17	12	38	130	240	21.2			
CH-HL 8 – 240	288	360	235	203	170	300	240	13	3 x 60	17	16	38	130	240	23.9			
CH-HL 8 – 320	288	360	235	203	170	380	320	13	4 x 60	17	20	38	130	240	29.3			
CH-HL 8 – 400	288	360	235	204	170	460	400	13	4 x 70	17	20	38	130	240	34.6			

load values, capacity limits

type	load		natural frequ. fe		dynam. spring ratio cd 960 min ⁻¹			capacity limits*											
	load		load		verti. N/mm	sw amplitude		720 min ⁻¹ (12 Hz)				960 min ⁻¹ (16 Hz)				1440 min ⁻¹ (24 Hz)			
	min. N	max. N	min. Hz	max. Hz		peak to peak mm	N/ mm	sw mm	K -	W %	Vm m/min.	sw mm	K -	W %	Vm m/min.	sw mm	K -	W %	Vm m/min.
CH-I HL 3 – 40	120	300	5.7	4.6	26	7	15	8	2.3	84	9.5	7	3.5	91.1	10.8	5	5.8	96.2	11.7
CH-HL 7 – 110	2000	4500	3.2	2.8	161	14	86	17	4.9	93.7	20.5	14	7.1	96.8	22.5	8	9.3	98.6	18
CH-HL 8 – 120	3500	8400	2.6	2.8	281	15	117	18	5.3	94.2	21	15	7.7	96.8	24	8	9.3	98.6	18
CH-HL 8 – 160	4700	11300	2.6	2.8	378	15	157	18	5.3	94.2	21	15	7.7	96.8	24	8	9.3	98.6	18
CH-HL 8 – 200	6000	14000	2.6	2.8	467	15	196	18	5.3	94.2	21	15	7.7	96.8	24	8	9.3	98.6	18
CH-HL 8 – 240	7200	16000	2.6	2.8	528	15	230	18	5.3	94.2	21	15	7.7	96.8	24	8	9.3	98.6	18
CH-HL 8 – 320	9000	22000	2.6	2.8	731	15	311	18	5.3	94.2	21	15	7.7	96.8	24	8	9.3	98.6	18
CH-HL 8 – 400	12000	27000	2.6	2.8	895	15	386	18	5.3	94.2	21	15	7.7	96.8	24	8	9.3	98.6	18

*sw: amplitude (peak to peak)

K: oscillating machine factor

W: isolation efficiency

Vm: theo. conveying speed (angle 45°)